

LOC	DIST	REVISIONS			
F	CHR	DESCRIPTION	DATE	ENR	APVD
L		REVISED PER EC 063B-0295-00	23-JUN-00	LM	KC

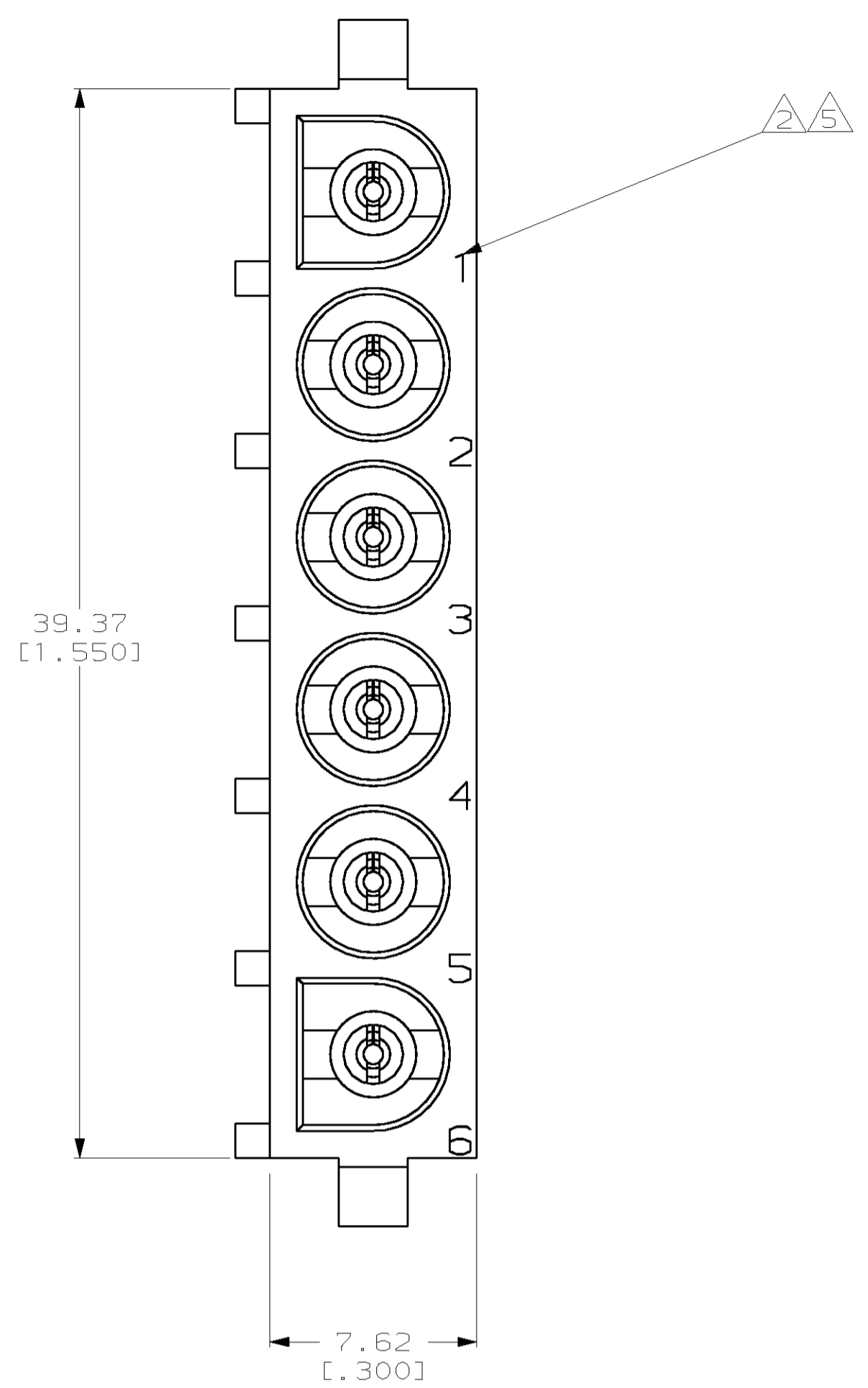

- PARTS COMPLY TO AMP SOLDERABILITY SPECIFICATION 109-11-3.
- CIRCUIT IDENTIFICATION CHARACTERS ARE ADJACENT TO THE INDICATED CAVITIES, BUT LOCATION AND ORIENTATION MAY DIFFER FROM PRINT.
- DIMENSIONS IN BRACKETS ARE IN INCHES.
- IDENTIFICATION WILL APPEAR AT CIRCUIT NO. 1, OTHERS OPTIONAL.

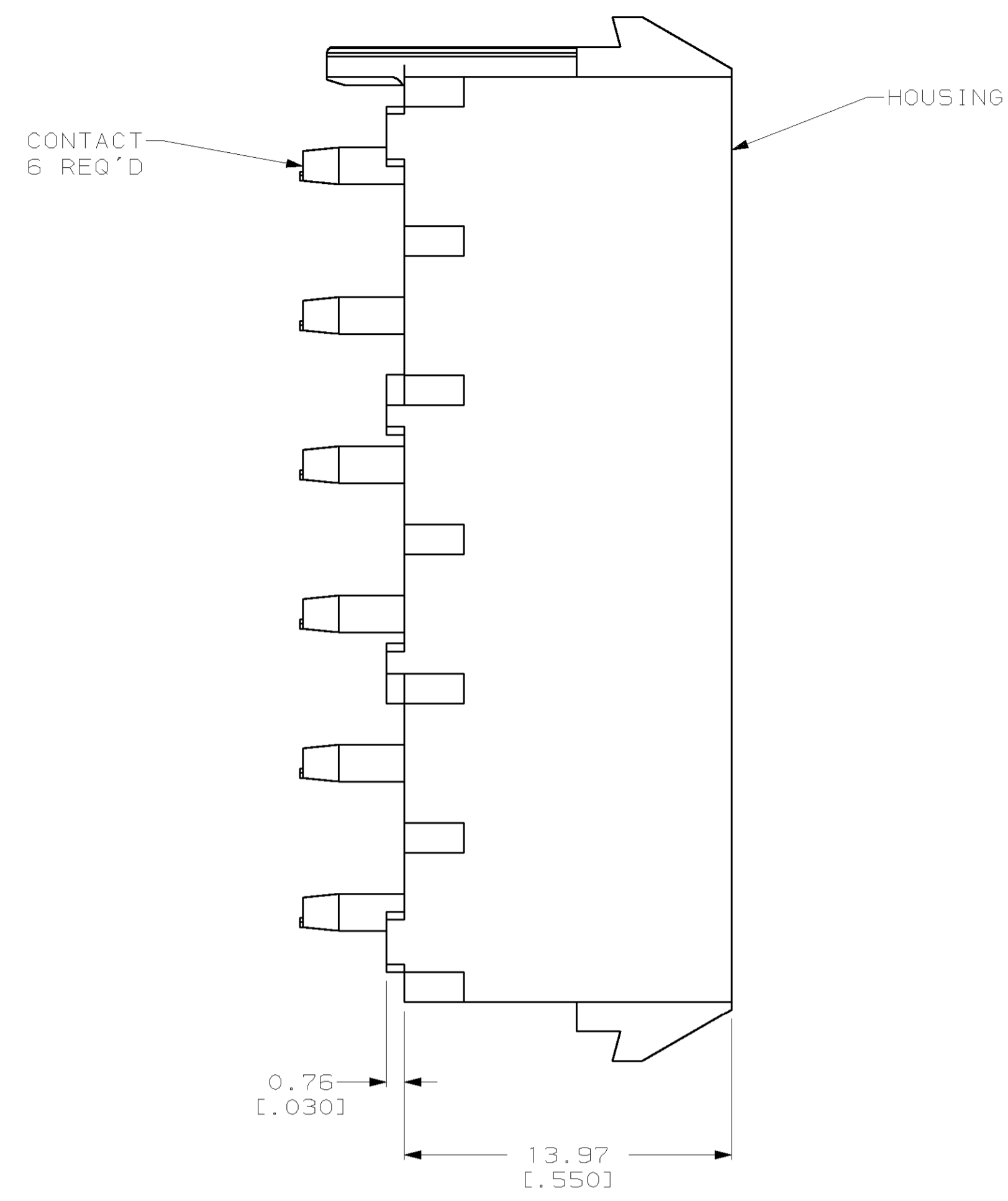
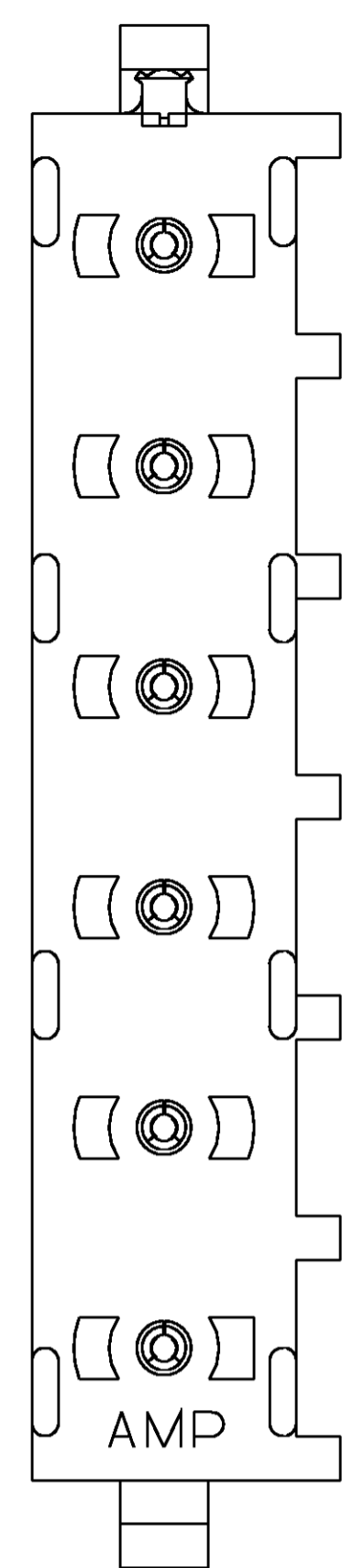
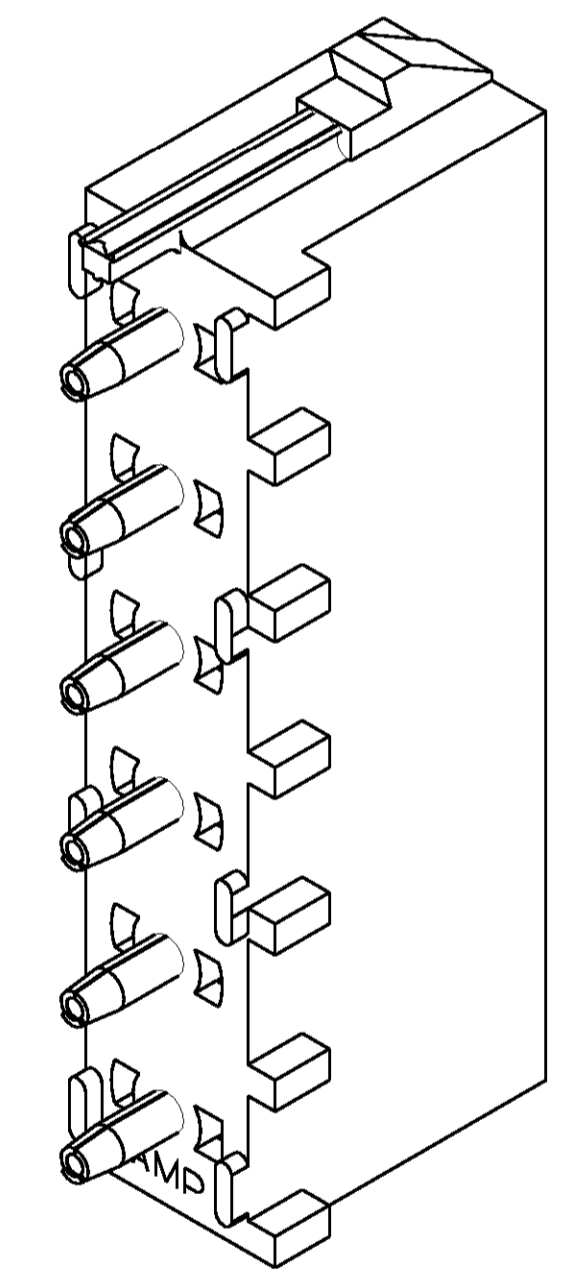
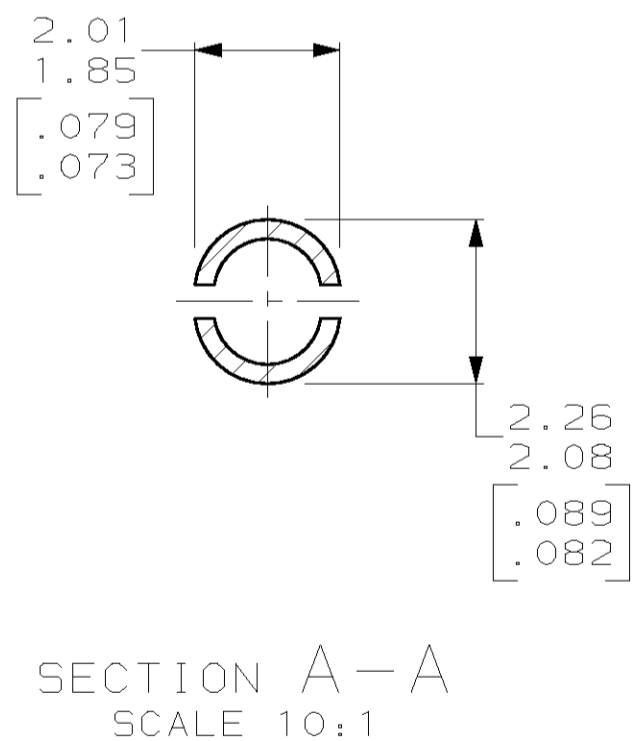
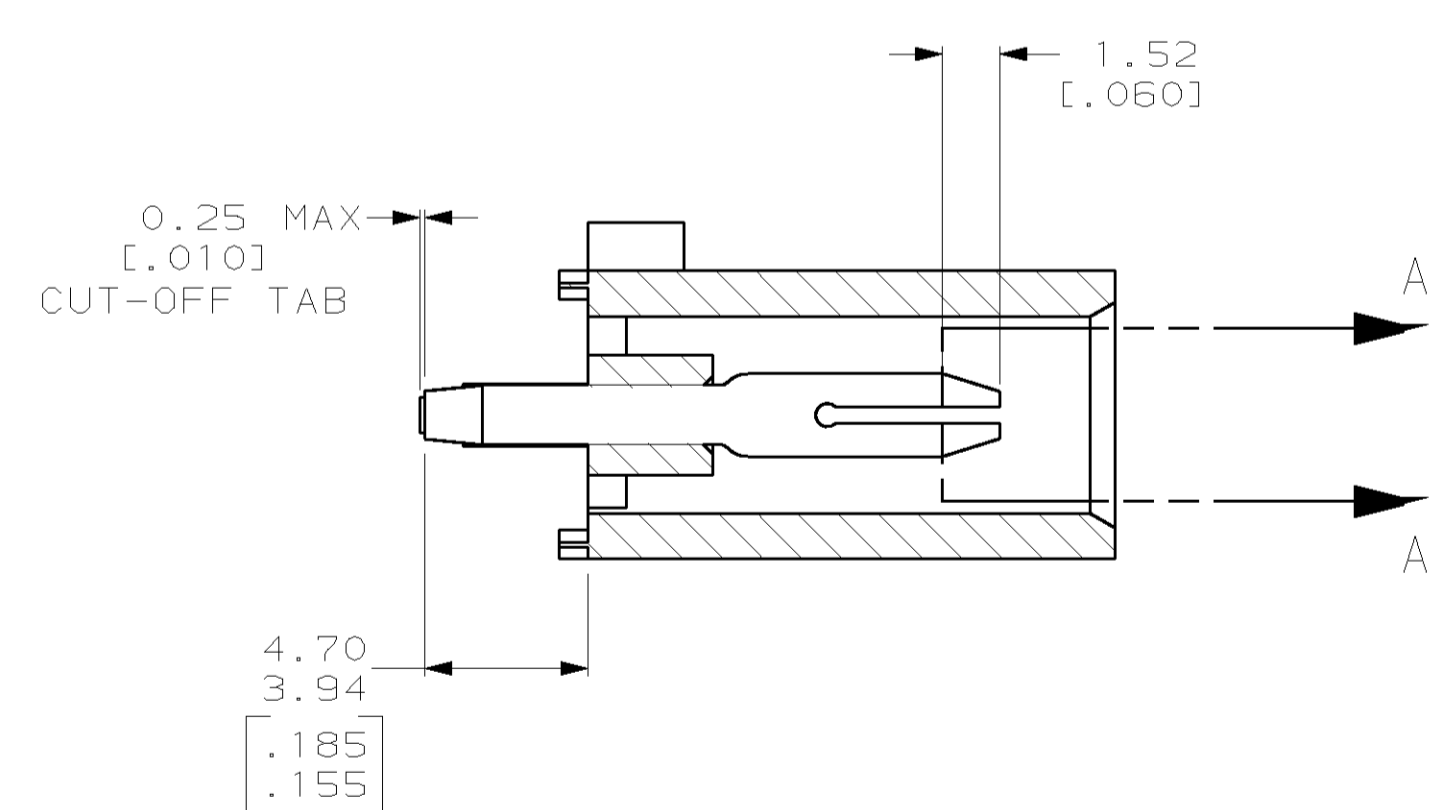

3-DIMENSIONAL MODEL
NTS

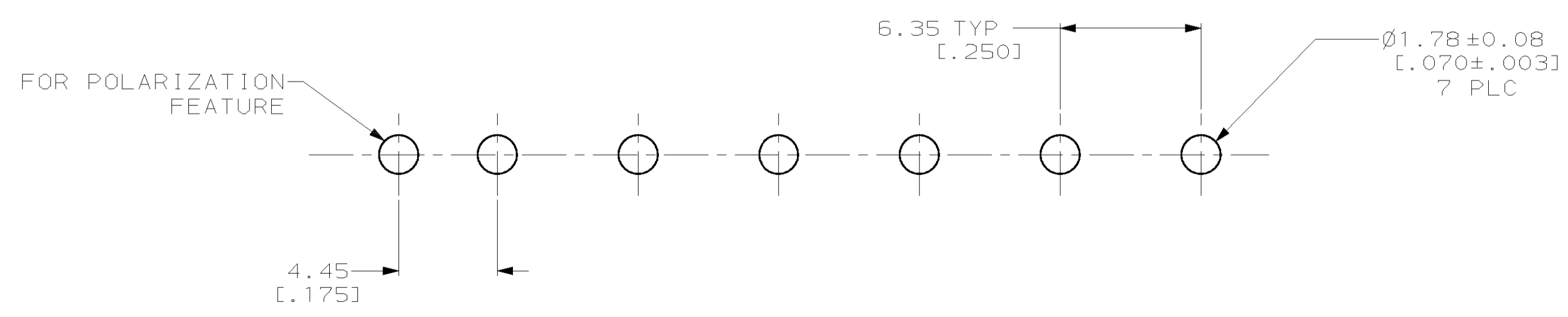

RECOMMENDED MOUNTING HOLE PATTERN
FOR 1.57 [.062] THICK P.C. BOARD

PHOSPHOR BRONZE, PRE-TIN PIN CONTACT MATERIAL AND FINISH	NYLON, UL94V-2, NATURAL HOUSING MATERIAL	643407-1 PART NO
THIS DRAWING IS A CONTROLLED DOCUMENT.		
DIMENSIONS: mm (INCHES)	TOLERANCES UNLESS OTHERWISE SPECIFIED:	DWN L. McEACHIN 07-JAN-2000 CHK K. COBLE 07-JUN-2000 APVD K. COBLE 07-JUN-2000
0 PLC ± 1 PLC ± 2 PLC ±0.13 (.005) 3 PLC ± 4 PLC ±	ANGLES 40°-90°	NAME: AMP Incorporated Harrisburg, PA 17105-3608
MATERIAL SEE TABLE	FINISH SEE TABLE	SIZE: A1 CAGE CODE: 00779 DRAWING NO: C-643407
CUSTOMER DRAWING		SCALE: 5:1 SHEET: 1 OF 1 REV: L

